

# Operation and Start-up

---

## Preparation

Perform the following checks and inspections before operating the unit :

### Inspection Checklist

- Unit is mounted securely to the ceiling support rods (mounting units.)
- Ductwork connections are complete.
- Coil connections are complete and tight.
- Condensate drain pan connections are complete and tight.
- Electrical connections are completed. Wiring is correct and in accordance with the wiring diagram.
- Ground connection is completed.
- Check and retighten if necessary set screws on the drive, fan pulley, fan bearings and wheel.
- Rotate fan by hand, to ensure that it runs freely and that there is no interference.
- Check that fan is centrally located in the housing, axially and radially.
- Check and retighten, if necessary, drive and bearing bolts, motor clamp plate bolts and isolator bolts.
- Check to ensure that pulley are correctly aligned and that shafts are parallel.
- Check belt tension as per instruction given in the maintenance section.

### Start-Up Procedures

After completing all times under "Pre-Start-Up", the unit may be started and the following checks and adjustments performed.

- a. Measure the motor voltage and amps on all phases to insure proper operation. Compare these readings with the motor nameplate.
- b. Disconnect load and start motor to check the direction of rotation. If the rotation need to be changed, stop the motor completely and change the direction of rotation.
- c. After connecting the load, the motor should start quickly and run smoothly. If it does not, the power supply should be switched off at once and all connections, as well as the power supply, be re-checked before re-starting.
- d. In the event of excessive vibrations or unusual noises, the motor should be disconnected from the load and checked for poor alignment, loose mounting bolts, etc.
- e. When the motor has been operated under load for a short period of time, check that the operating current totally with the nameplate current.

## Maintenance

**⚠ WARNING :** DISCONNECT ELECTRICAL POWER SOURCE AND SECURE IN DISCONNECTED POSITION BEFORE SERVICING THE UNIT. FAILURE TO DO SO MAY RESULT IN PERSONAL INJURY OR DEATH FROM ELECTRICAL SHOCK.

### Monthly Inspection

1. Check condition of air filters and replace them if necessary.
2. Check the drain pan to be sure that it is clean and free to carry the flow of condensate through the drain line.
3. Check the coil surface for cleanliness. Clean if necessary.

### Yearly Inspection

1. Replace filters.
2. Check coil surface. Clean by vacuuming or flushing with cold water. Do not use steam or hot water.
3. Carry out checks as detailed in inspection checklist in the Operation Section.
4. Inspect the condition of the evaporator fan belt and replace if necessary. The belts fitted to TTH units cannot achieve design performance without the correct tensioning.
5. Check condition of vibration isolators, replace if there is any sign of wear, loosening or material deterioration.
6. Check fan bearings for noisy operation and excessive lubricant leakage. Replace if necessary.
7. Inspect the condensate drain pan and condensate piping to make sure they are clear and will carry away all water.
8. Inspect the control panel wiring to make sure connections are tight and insulation is intact.

### Change / Clean Filters

Change or clean air filters at least twice a year. Filters will be required more frequent care under high load conditions or dirty air. A clogged air filters reduces airflow, cooling capacity and increases energy usage.

To clean permanent filters, remove the filter media and wash it in water to remove dust, dirt and lint ; allow to dry thoroughly before re-installing in the units. Do not rub or wring.

Permanent filters can also be cleaned by blowing with compressed air in opposite direction of filter airflow.

### Belt Maintenance

Clean fan belts and pulleys with a dry cloth. Oil and grease must be kept off belts. The use of a belt dressing is not recommended. When replacing belts, use a matched set.

Do not force belts onto pulleys, but adjust motor position to allow mounting and then re-tighten.

**Figure 9 : Belt Tension Measurement**

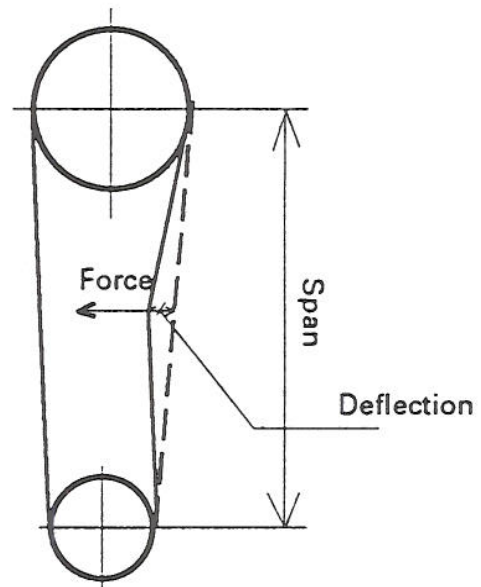

To measure belt tension, use a belt tensioner as shown in Figure 9. Determine actual deflection by depressing one belt with the belt tensioner and then adjust the belt tension to the correct pounds force and tighten all setscrews to the proper torques.